

Versatile DC/DC Converter

FEATURES

- 3V to 30V Input Voltage Operation.
- Internal 2A Peak Current Switch.
- 1.5A Continuous Output Current.
- Bootstrapped Driver.
- High Side Current Sense Capability.
- High Efficiency (up to 90%).
- Internal $\pm 2\%$ Reference.
- Low Quiescent Current at 1.6mA.
- Frequency Operation from 100Hz to 100KHz.

APPLICATIONS

- Constant Current Source for Battery Chargers.
- Saver for Cellular phones.
- Step-Down DC-DC Converter Module.

DESCRIPTION

The AIC1563 is a monolithic control circuit containing the primary functions required for DC to DC converters and highside-sensed constant current source. The device consists of an internal temperature compensated reference, comparator, controlled duty cycle oscillator with an active current sense circuit, bootstrapped driver, and high current output switch. This device is specifically designed to construct a constant current source for battery chargers with a minimum number of external components. Bootstrapped driver can drive the NPN output switch to saturation for higher efficiency and less heat dissipation. The AIC1563 can deliver 1.5A continuous current without requiring a heat sink.

TYPICAL APPLICATION CIRCUIT

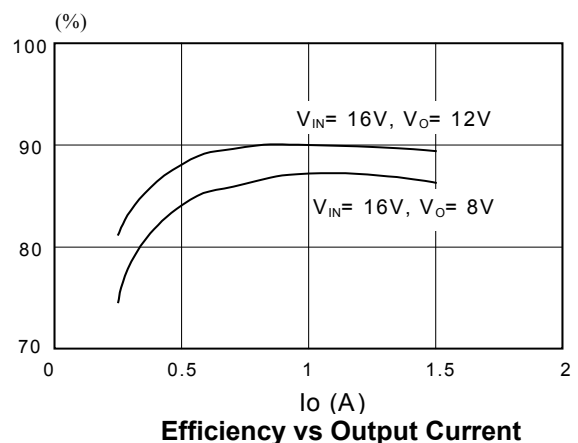
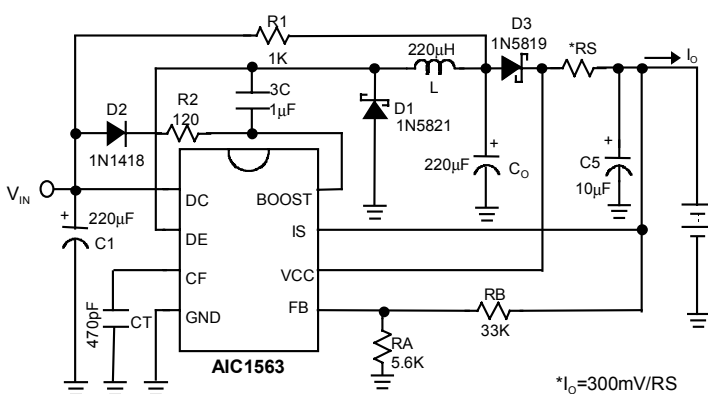

ORDERING INFORMATION

AIC1563 XX

PACKAGE TYPE
 N: PLASTIC DIP
 S: SMALL OUTLINE

TEMPERATURE
 C: 0°C~+70°C

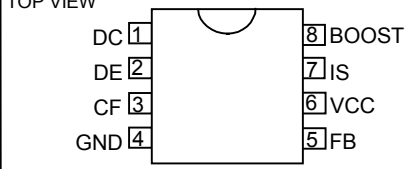
ORDER NUMBER	PIN CONFIGURATION
AIC1563CN (PLASTIC DIP)	TOP VIEW 
AIC1563CS (PLASTIC SO)	

ABSOLUTE MAXIMUM RATINGS

Supply Voltage	30V
Comparator Input Voltage Range	-0.3V~30V
Switch Collector Voltage	30V
Switch Emitter Voltage	30V
Switch Collector to Emitter Voltage	30V
Driver Collector Voltage	30V
Switch Current	2A
Power Dissipation and Thermal Characteristics	
DIP Package	
Ta= 25°C	1.0W
Thermal Resistance	100°C/W
SO Package	
Ta= 25°C	625mW
Thermal Resistance	160°C/W
Operating Junction Temperature	125°C
Operating Ambient Temperature Range	0~70°C
Storage Temperature Range	- 65°C ~ 150°C

TEST CIRCUIT

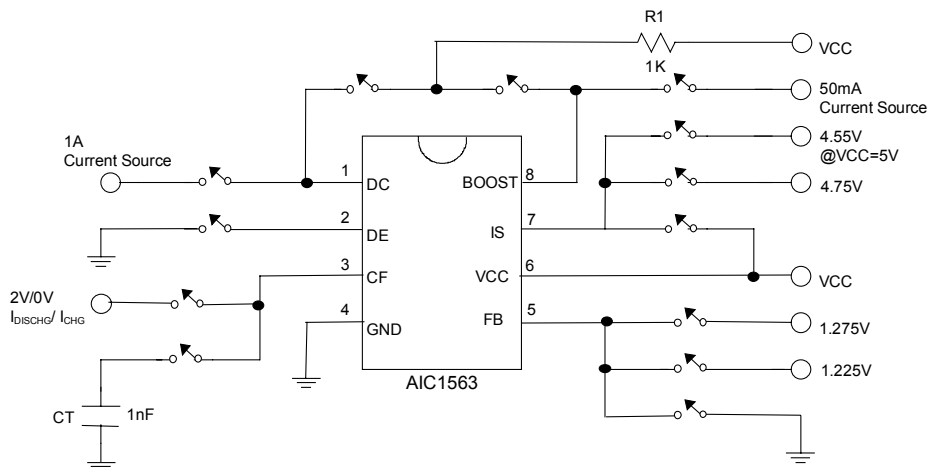

ELECTRICAL CHARACTERISTICS ($V_{CC}=5V$, $T_a=25^{\circ}C$, unless otherwise specified.)

PARAMETER	TEST CONDITIONS	SYMBOL	MIN.	TYP.	MAX.	UNIT
Oscillator						
Charging Current	$5.0V \leq V_{CC} \leq 30V$	I_{CHG}	10	25	40	μA
Discharge Current	$5.0V \leq V_{CC} \leq 30V$	I_{DISCHG}	100	150	200	μA
Voltage Swing	PIN 3	V_{OSC}		0.6		V
Discharge to Charge Current Ratio	$V_{IS} = V_{CC}$	I_{DISCHG} / I_{CHG}		6.0		
Current Limit Sense Voltage	$I_{CHG} = I_{DISCHG}$	$V_{CC} - V_{IS}$	250	300	350	mV
Output Switch						
Saturation Voltage, Emitter Follower Connection	$I_{DE} = 1.0A$; $V_{BOOST} = V_{DC} = V_{CC}$	$V_{CE(SAT)}$		1.5	1.8	V
Saturation Voltage	$I_{DC} = 1.0A$; $I_{BOOST} = 50mA$, (Forced $\beta \approx 20$)	$V_{CE(SAT)}$		0.4	0.7	V
DC Current Gain	$I_{SC} = 1.0A$; $V_{CE} = 5.0V$	h_{FE}	35	120		
Collector Off-State Current	$V_{CE} = 30V$	$I_{C(OFF)}$		10		nA
Comparactor						
Threshold Voltage	$T_a = 25^{\circ}C$ $0^{\circ}C \leq T_a \leq 70^{\circ}C$	V_{FB}	1.225	1.25	1.275	V
			1.21		1.29	V
Threshold Voltage Line Regulation	$3.0V \leq V_{CC} \leq 30V$	REG_{LINE}		0.1	0.3	mV/V
Input Bias Current	$V_{IN} = 0V$	I_{IB}		0.4	1	μA
Supply Current	$V_{IS} = V_{CC}$, pin 5 $> V_{FB}$ $5.0V \leq V_{CC} \leq 30V$ $C_T = 1nF$ PIN 2=GND Remaining pins open	I_{CC}		1.6	3	mA

TYPICAL PERFORMANCE CHARACTERISTICS

Output Switch ON-OFF Time vs Oscillator Timing Capacitor

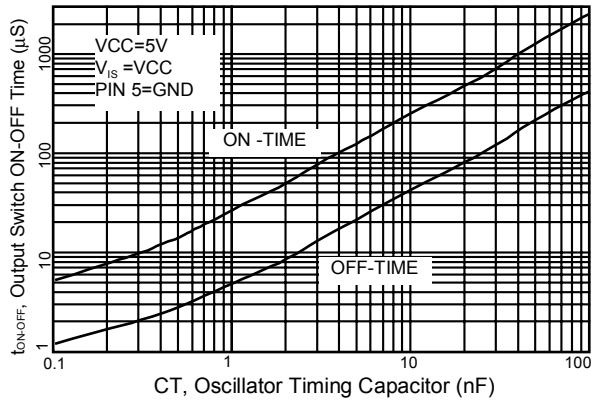

Standby Supply Current vs Supply Voltage

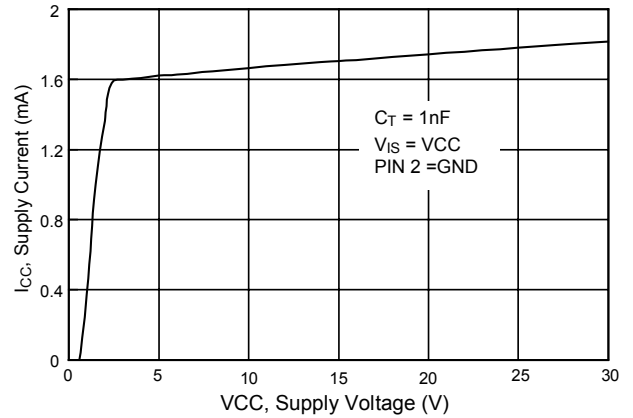

V_{FB}, Threshold Voltage vs Temperature

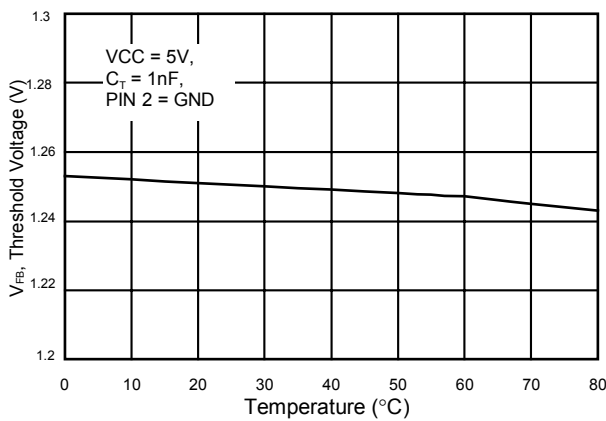

I_S Threshold Voltage vs Temperature

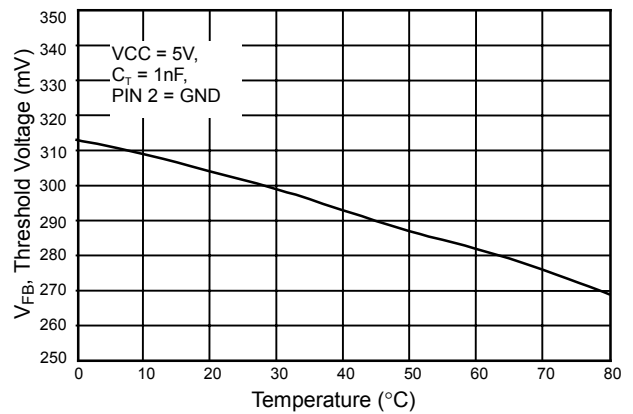

Emmitter Follower Configuration Output Switch Saturation Voltage vs Emmitter Current

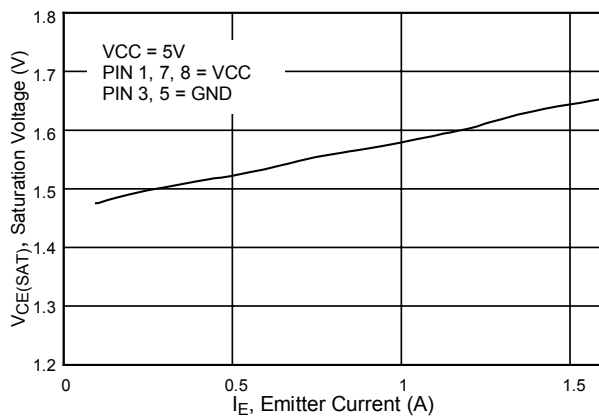

Common Emmitter Configuration Output Switch Saturation Voltage vs Collector Current

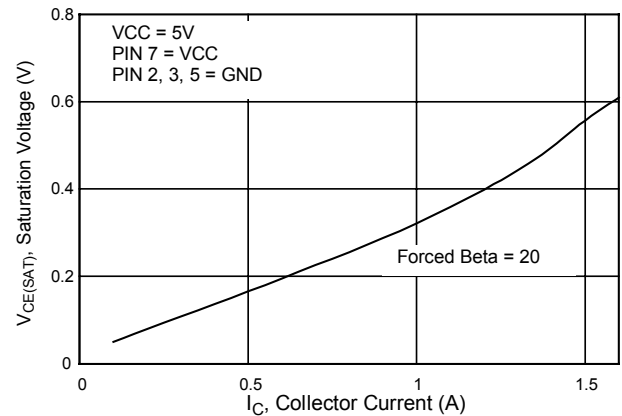

■ BLOCK DIAGRAM

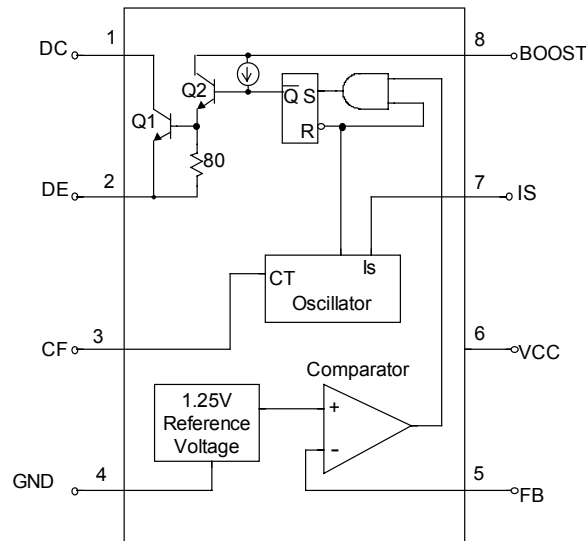

■ PIN DESCRIPTIONS

- | | |
|--|---|
| PIN 1: DC - 2A switch collector. | PIN 5: FB - Feedback comparator inverting input. |
| PIN 2: DE - Darlington switch emitter. | PIN 6: VCC - Power supply input. |
| PIN 3: CF - Oscillator timing capacitor. | PIN 7: IS - Highside current sense input.
VCC - $V_{IS}=300mV$. |
| PIN 4: GND - Power ground. | PIN 8: BOOST-Bootstrapped driver collector. |

■ APPLICATION INFORMATIONS

● DESIGN FORMULA TABLE

CALCULATION	STEP-DOWN	STEP-UP
$\frac{t_{ON}}{t_{OFF}}$	$\frac{V_{OUT} + V_F}{V_{IN(MIN)} - V_{SAT} - V_{OUT}}$	$\frac{V_{OUT} + V_F - V_{IN(MIN)}}{V_{IN(MIN)} - V_{SAT}}$
$(t_{ON} + t_{OFF})_{MAX}$	$\frac{1}{F_{MIN}}$	$\frac{1}{F_{MIN}}$
C_T	$4 \times 10^{-5} t_{ON}$	$4 \times 10^{-5} t_{ON}$
$I_C(SWITCH)$	$2I_{OUT(MAX)}$	$2I_{OUT(MAX)} \left(\frac{t_{ON} + t_{OFF}}{t_{OFF}} \right)$
RS	$0.3/I_C(SWITCH)$	$0.3/ I_C(SWITCH)$
L(MIN)	$\left(\frac{V_{IN(MIN)} - V_{SAT} - V_{OUT}}{I_C(SWITCH)} \right) t_{ON(MAX)}$	$\left(\frac{V_{IN(MIN)} - V_{SAT}}{I_C(SWITCH)} \right) t_{ON(MAX)}$
C_o	$\frac{I_C(SWITCH) (t_{ON} + t_{OFF})}{8V_{RIPPLE(P - P)}}$	$\frac{I_{OUT} t_{ON}}{V_{RIPPLE(P - P)}}$

V_{SAT} = Saturation voltage of the output switch.
 V_F = Forward voltage of the ringback rectifier

F_{MIN} - Minimum desired switching frequency at selected values for V_{IN} and I_{OUT} .

The following power supply characteristics must be chosen:

$V_{RIPPLE (P-P)}$ - Desired peak-to-peak output ripple voltage. In practice, the calculated value will need to be increased due to the capacitor equivalent series resistance and board layout. The ripple voltage should be kept to a low value since it will directly affect the line and load regulation.

V_{IN} - Nominal input voltage.

V_{OUT} - Desired output voltage,
 $V_{OUT} = 1.25 (1 + RB/RA)$

I_{OUT} - Desired output current.

APPLICATION EXAMPLES

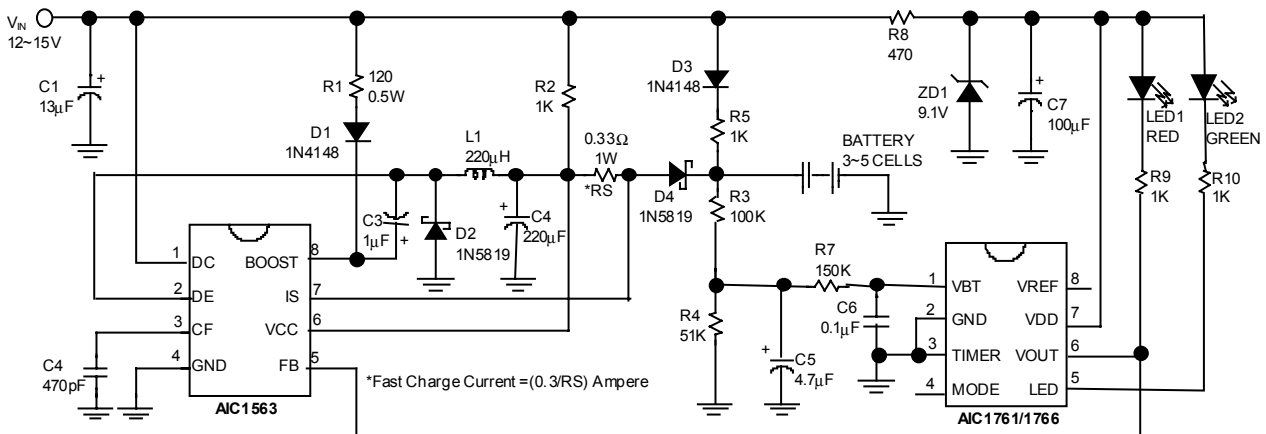

Fig. 1 Simplified Battery Charge Circuit for Ni-Cd/ Ni-MH Battery

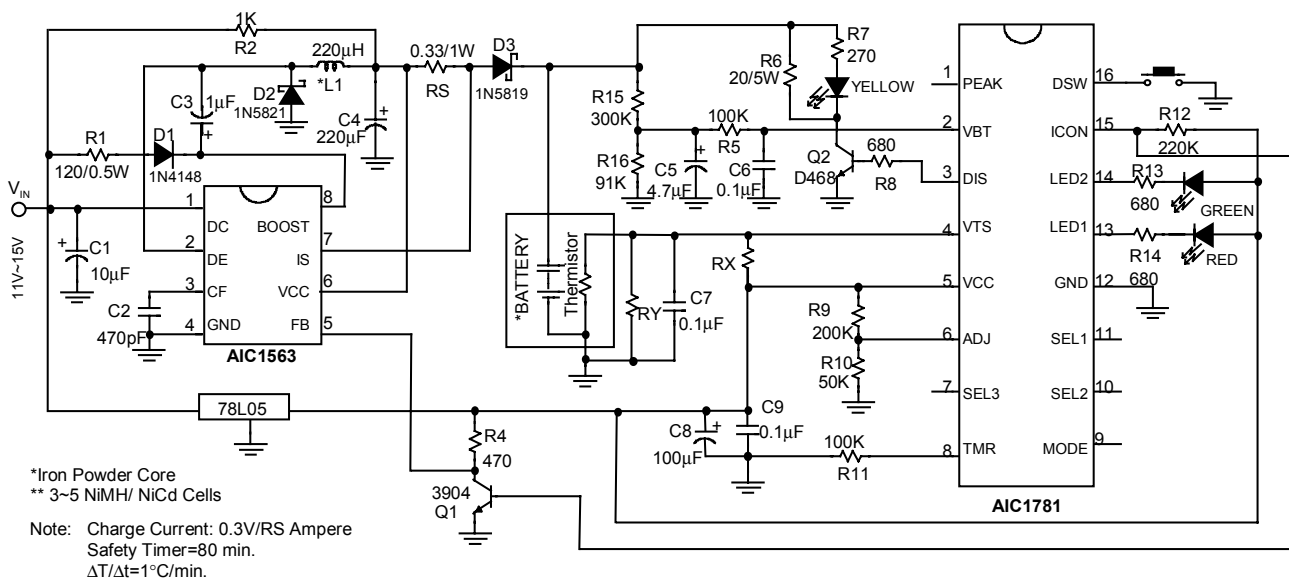
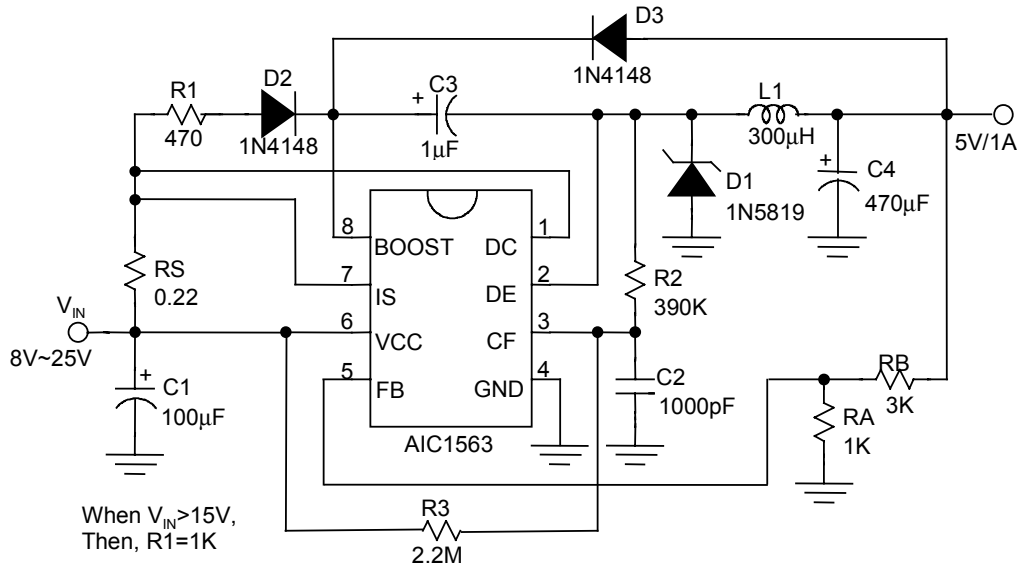

Fig. 2 Battery Charge Circuit for Fluctuating Charging Current Applications

APPLICATION EXAMPLES (CONTINUED)



Line Regulation	$V_{IN} = 10V \sim 20V @ I_o = 1A$	40mV
Load Regulation	$V_{IN} = 15V, @ I_o = 100mA \sim 1A$	20mV
Short Circuit Current	$V_{IN} = 15V, @ R_L = 0.1\Omega$	1.3A

Fig. 3 Step-Down Converter

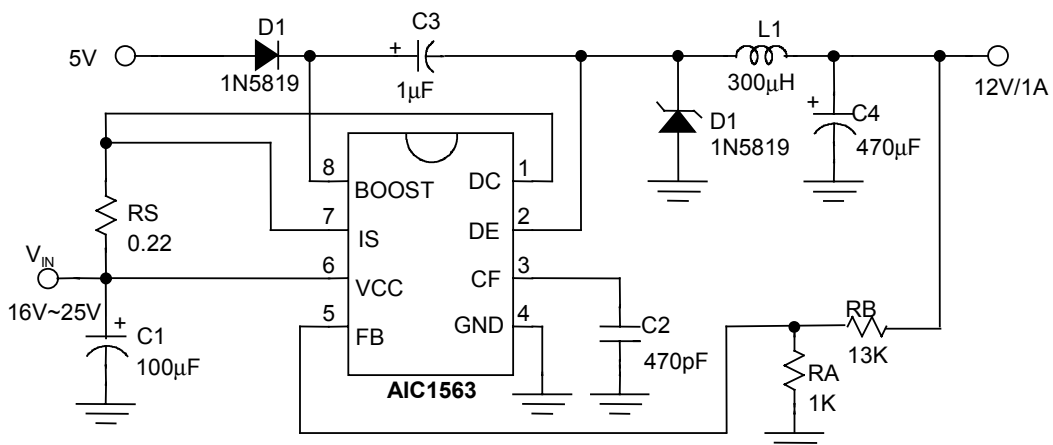
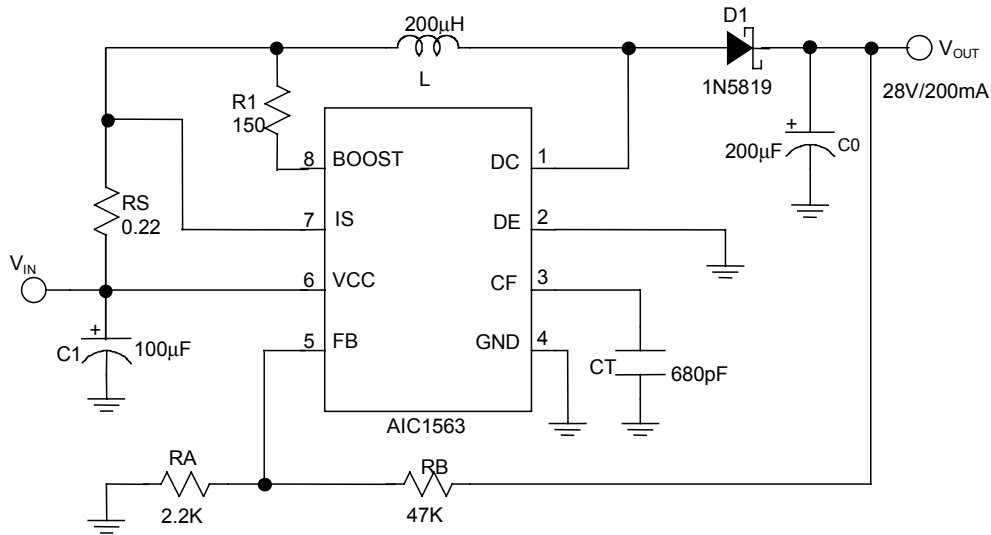

Fig. 4 Step-Down Converter with External 5V Bootstrap

■ APPLICATION EXAMPLES (CONTINUED)



Line Regulation	$V_{IN} = 8V \sim 16V @ I_O = 200mA$	100mV
Load Regulation	$V_{IN} = 12V, @ I_O = 80mA \sim 200mA$	40mV

Fig. 5 Step-Up Converter

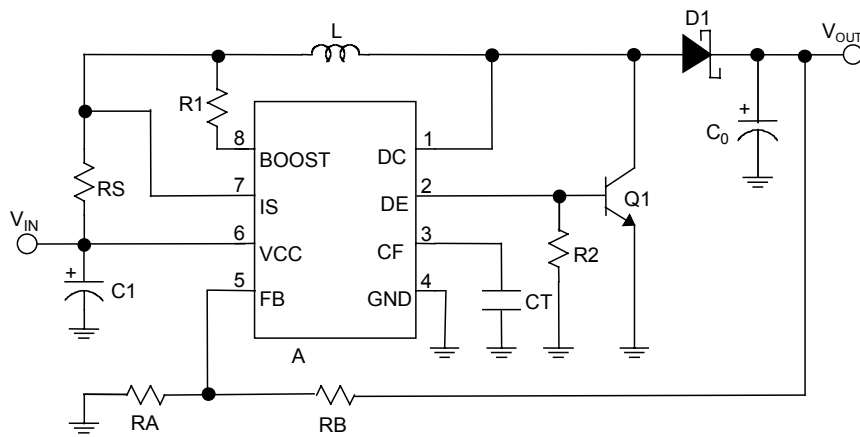
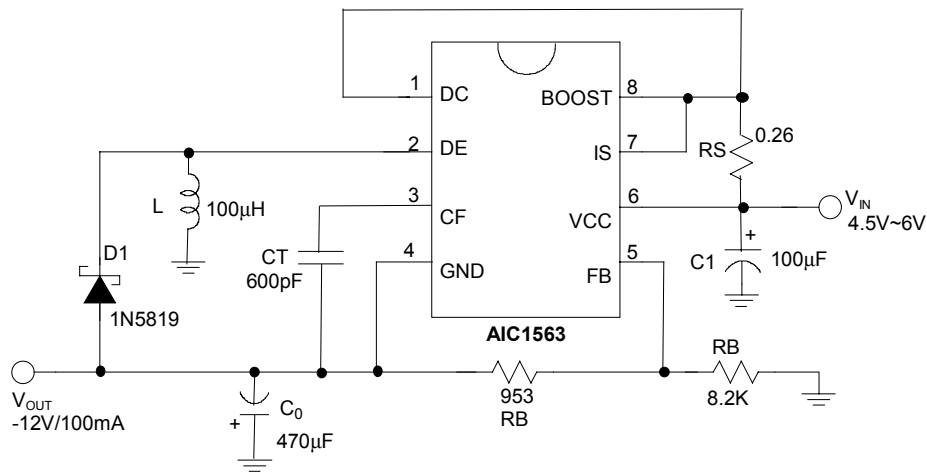

Fig. 6 Step-Up Converter with External NPN Switch

APPLICATION EXAMPLES (CONTINUED)

Line Regulation	$V_{IN} = 4.5V \sim 6V @ I_O = 100mA$	20mV
Load Regulation	$V_{IN} = 5V, @ I_O = 10mA \sim 100mA$	100mV

Fig.7 Inverting Converter
PHYSICAL DIMENSIONS

- 8 LEAD PLASTIC SO (unit: mm)

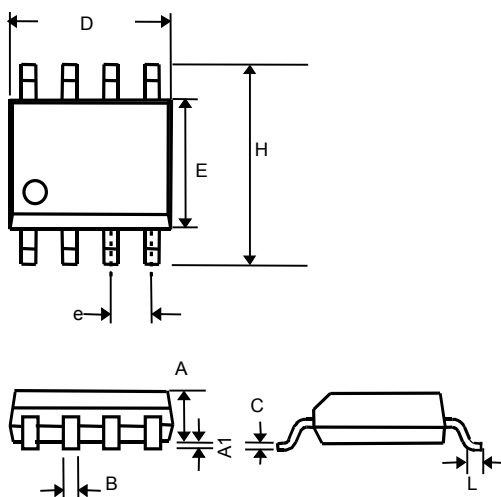

SYMBOL	MIN	MAX
A	1.35	1.75
A1	0.10	0.25
B	0.33	0.51
C	0.19	0.25
D	4.80	5.00
E	3.80	4.00
e	1.27(TYP)	
H	5.80	6.20
L	0.40	1.27

● **8 LEAD PLASTIC DIP (unit: mm)**

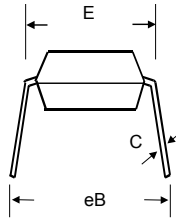
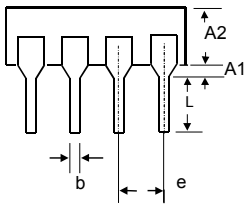
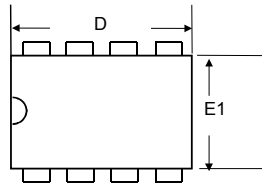

SYMBOL	MIN	MAX
A1	0.381	—
A2	2.92	4.96
b	0.35	0.56
C	0.20	0.36
D	9.01	10.16
E	7.62	8.26
E1	6.09	7.12
e	2.54 (TYP)	
eB	—	10.92
L	2.92	3.81